

## Lower Plate

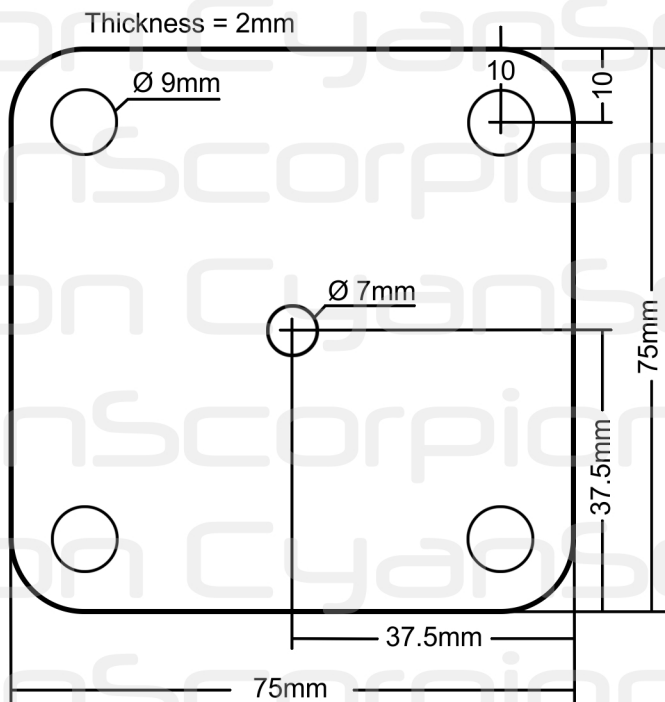

## Upper Plate

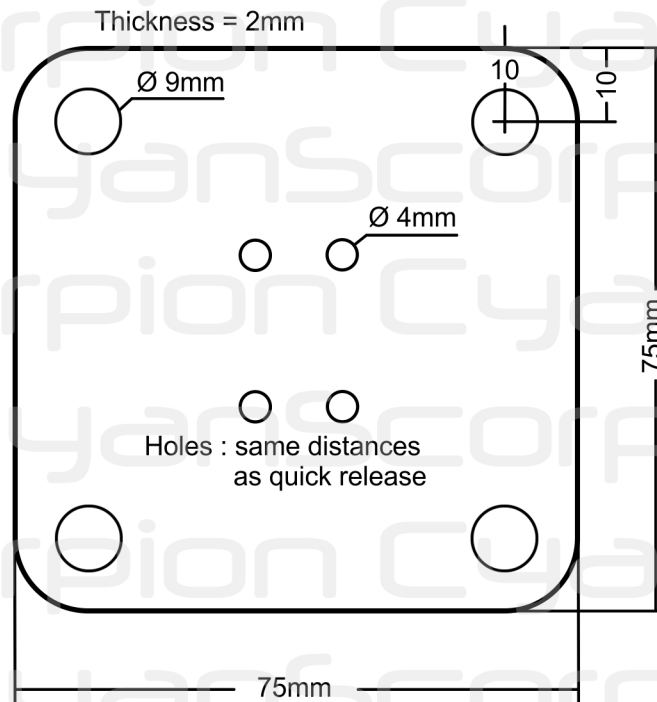

## Quick Release

Cullmann CX420

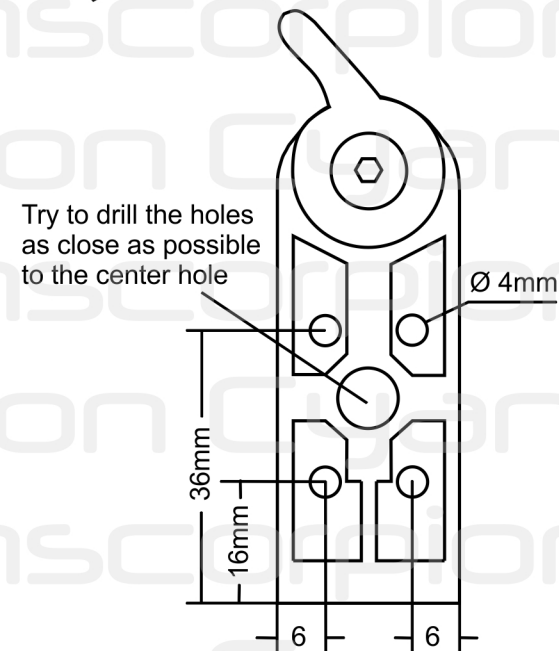

4 countersunk screws M3x15mm



4 self-locking nuts M3



4 washer

## Rubber

Thickness = 2mm

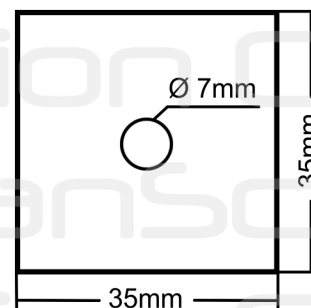

## Rubber

Thickness = 2mm

Dimensions : use quick release shape

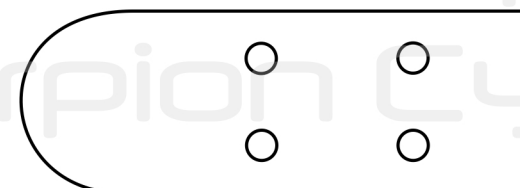

**Measures - Simple Multicopter Suspension Plate**